

DRG NO.

This document and any information or descriptive matter contained is communicated in confidence and is the copyright property of MSA BOLLARDS. Neither the whole or any extract may be disclosed, loaned, copied, or used for manufacturing or tendering purposes without their written consent. COPYRIGHT MSA BOLLARDS AS PER LATEST DATE OF ISSUE SHOWN BELOW

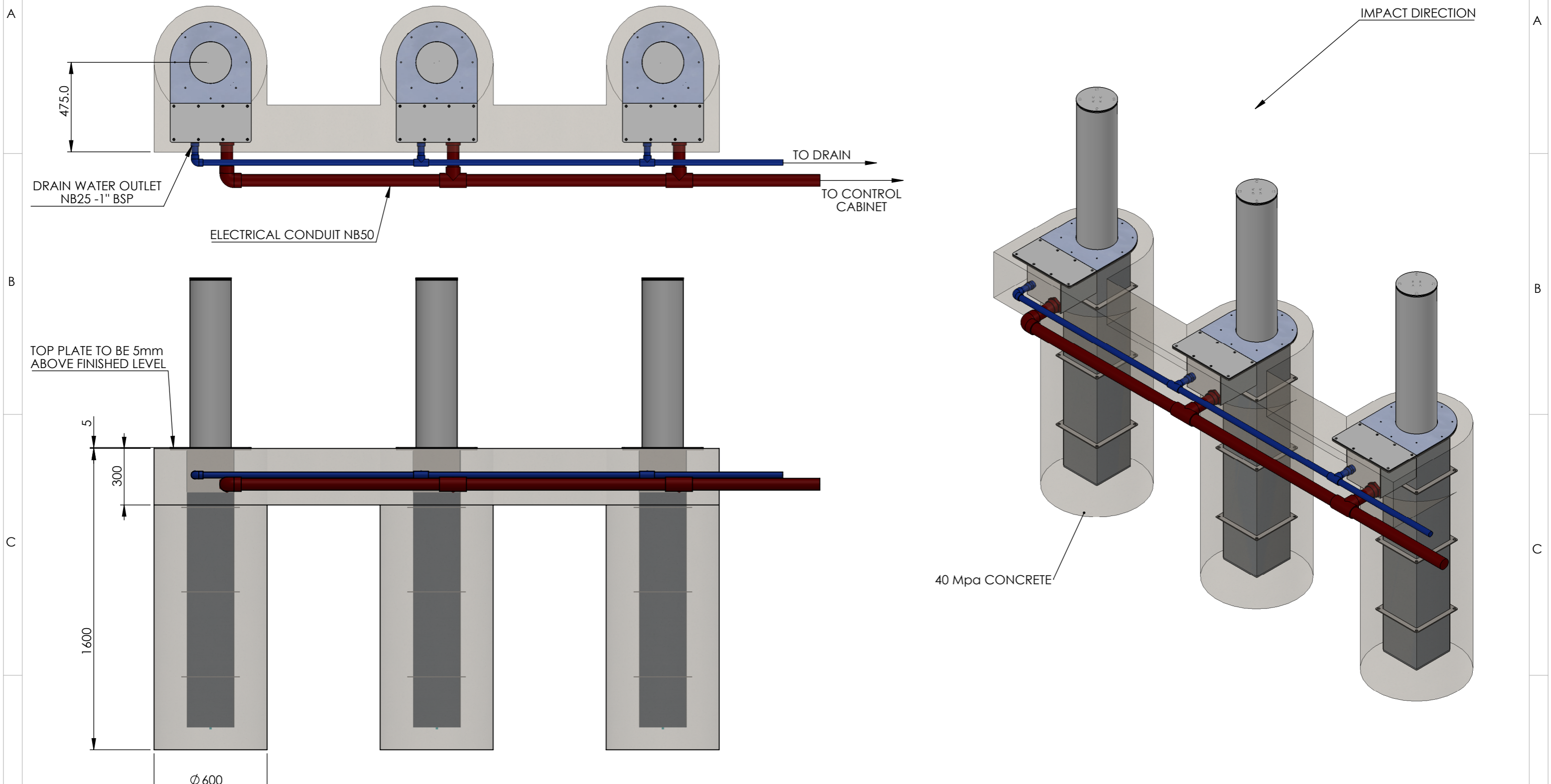

TOLERANCES UNLESS NOTED OTHERWISE

X	-	LINEAR	1mm	ANGULAR	0.5Deg
X.X	-		0.5mm		
X.XX	-		0.05mm		

DIMENSIONS IN mm UNLESS NOTED

JOB NO.		
DRAWN	WM	25/4/2015
CHECKED	-	-
APPROVED	-	-
PROJECTION		
THIRD ANGLE		

		MSA BOLLARDS Unit 2, 4 Kiwi Court Lonsdale 5160, SA ABN: 29 761 221 955	
TITLE			
ELECTRIC BOLLARD INSTALLATION INSTRUCTIONS			
CODE IDENT No.	DRG NO.	-	
SCALE 1:20	DRAWING STANDARD AS1100	SHT 1 OF 1	A3

NOTE: BEST VIEWED WHEN PRINTED IN A3 COLOUR

DO NOT SCALE

277